

TWO STAGE LIGHT OIL BURNERS

▶ **RL SERIES**

▶ RL 28	95/166 ÷ 332 kW
▶ RL 38	118/237 ÷ 450 kW
▶ RL 50	148/296 ÷ 593 kW
▶ RL 70	255/474 ÷ 830 kW
▶ RL 100	356/711 ÷ 1186 kW
▶ RL 130	486/948 ÷ 1540 kW
▶ RL 190	759/1423 ÷ 2443 kW

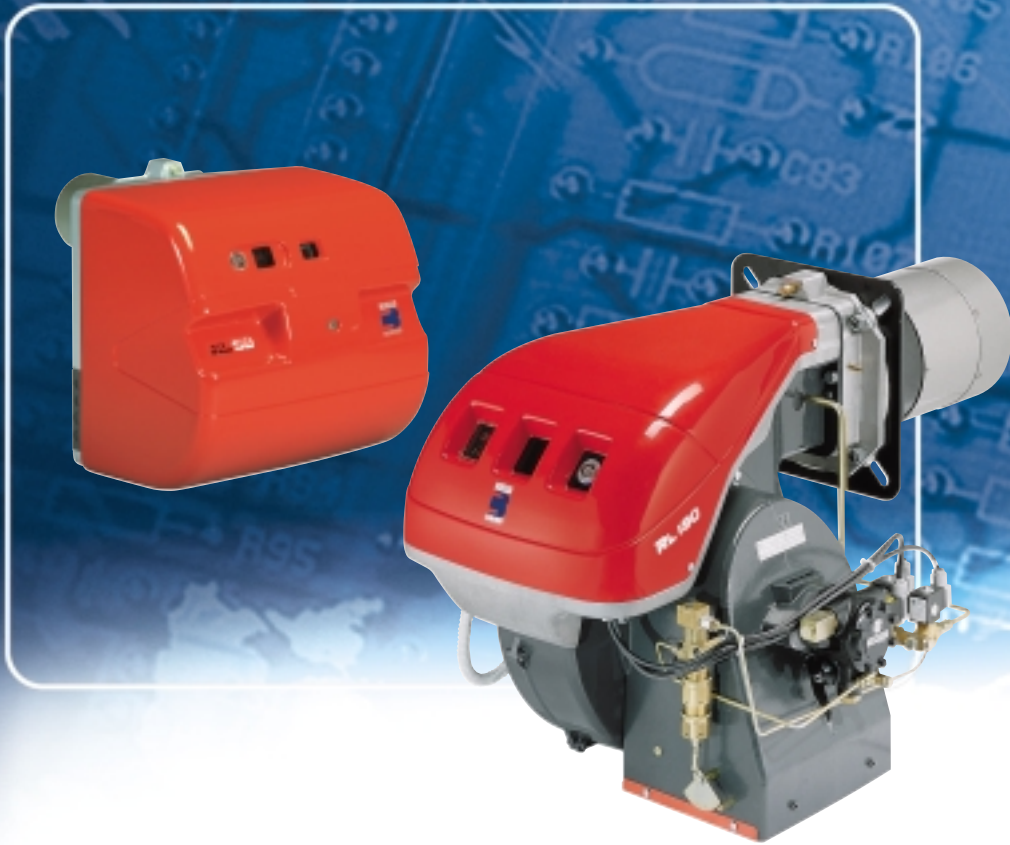

The RL series of burners covers a firing range from 95 to 2443 kW, and they have been designed for use in hot or superheater water boilers, hot air or steam generators, diathermic oil boilers.

Operation is "two stage"; the burners are fitted with an electronic device STATUS PANEL, which supplies complete diagnostic: hour meter, ignition meter, identification of trouble shooting.

Optimisation of sound emissions is guaranteed by the use of fans with forward inclined blades and sound deadening material incorporated in the air suction circuit. The elevated performance of the fans and combustion head, guarantee flexibility of use and excellent working at all firing rates.

The exclusive design ensures reduced dimensions, simple use and maintenance. A wide range of accessories guarantees elevated working flexibility.



TECHNICAL DATA

Model		▼ RL 28	▼ RL 38	▼ RL 38	▼ RL 50	▼ RL 70	▼ RL 100	▼ RL 130	▼ RL 190	
Burner operation mode	Two stage									
Modulation ratio to max. output	2 ÷ 1									
Servo-motor	type	--								
	run time	s								
Heat output	kW	95/166÷332	118/237÷450	118/237÷450	148/296÷593	255/474÷830	356/711÷1186	486/948÷1540	759/1423÷2443	
	Mcal/h	82/143÷286	101/204÷387	101/204÷387	127/255÷510	219/408÷714	306/612÷1020	418/816÷1325	653/1224÷2100	
	Kg/h	8/14÷28	10/20÷38	10/20÷38	12,5/25÷50	21,5/40÷70	30/60÷100	41/80÷130	64/120÷206	
Working temperature	°C min./max.	0/40								
Net calorific value	kWh/kg	11,8								
	Kcal/kg	10200								
Viscosity at 20°C	mm ² /s (cSt)	4 ÷ 6								
Pump	type	AN 57C	AL 65C		AL 75C	AL 95C	AJ 6CC		J7C	
	output	kg/h at 12 bar	45	67	88	107	164		230	
Atomised pressure	bar	12								
Oil temperature	Max. °C	50								
Fan	type	Centrifugal with reverse curve blades							Straight blades	
Air temperature	Max. °C	60								
Electrical supply	Ph/Hz/V	1/50/230-(±10%)			3N/50/400-(±10%)			3/50/230-(±10%) △		
Auxiliary electrical supply	Ph/Hz/V	1/50/230-(±10%)								
Control box	type	RB0 522								
Total electrical power	kW	0,37	0,6	0,56	0,75	1,4	1,8	2,6	5,9	
Auxiliary electrical power	kW	0,22	0,18	0,11	0,10	0,3	0,3	0,4	1,4	
Protection level	IP	44								
Power electric motor	kW	0,25	0,42	0,45	0,65	1,1	1,5	2,2	4,5	
Rated motor current	A	2,1	2,9	2 - 1,2	3 - 1,7	4,8 - 2,8	5,9 - 3,4	8,8 - 5,1	15,8 - 9,1	
Motor start current	A	4,8	11	9,5 - 5,5	13,8 - 8	25 - 14,6	27,7 - 16	57,2 - 33,2	126 - 73	
Motor protection level	IP	54								
Ignition transformer	V1 - V2	230V - 2x5 kV							230V - 2x5 kV	
	I1 - I2	1,9A - 30 mA							1,9A - 35 mA	
Working	Intermittent (at least one stop every 24 h)									
Sound pressure	dBA	68	70	70	75	75	77	78,5	83,9	
Sound output	W	--	--	--	--	--	--	--	--	
CO emission	mg/kWh	< 40								
Grade of smoke indicator	N° Bach.	< 1								
C _x H _y emission	mg/kWh	<10 (after the first 20 s.)								
NO _x emission	mg/kWh	< 200								
Directive	73/23 - 89/336 - 98/37 - 92/42 EEC									
According to	EN 267									
Certification		DIN 5G224/93	DIN 5G225/93	DIN 5G225/93	DIN 5G226/93	DIN 5G424/99	DIN 5G425/99	DIN 5G426/99	DIN 5G861/98	

Reference conditions:
 Temperature: 20°C
 Pressure: 1013.5 mbar
 Altitude: 100 m a.s.l.
 Noise measured at a distance of 1 meter.

Since the Company is constantly engaged in the production improvement, the aesthetic and dimensional features, the technical data, the equipment and the accessories can be changed.
 This document contains confidential and proprietary information of RIELLO S.p.A. Unless authorised, this information shall not be divulged, nor duplicated in whole or in part.



FIRING RATES

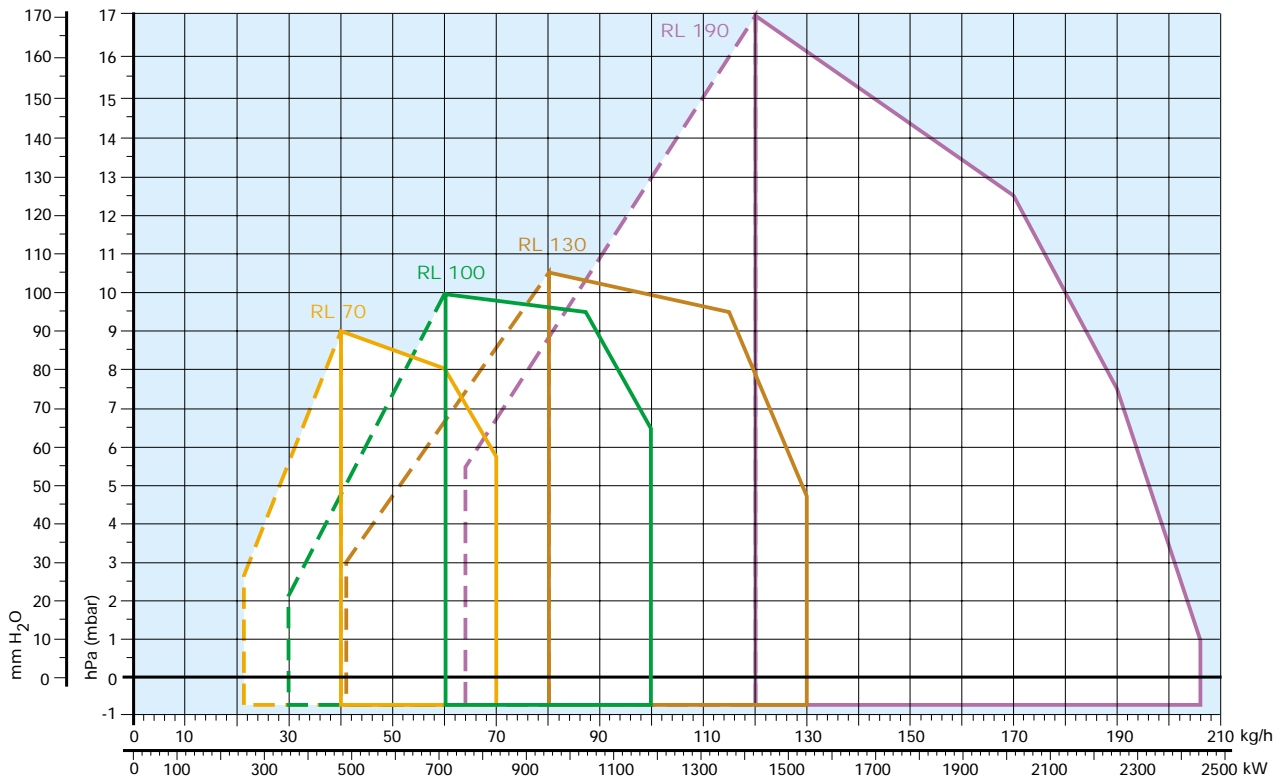
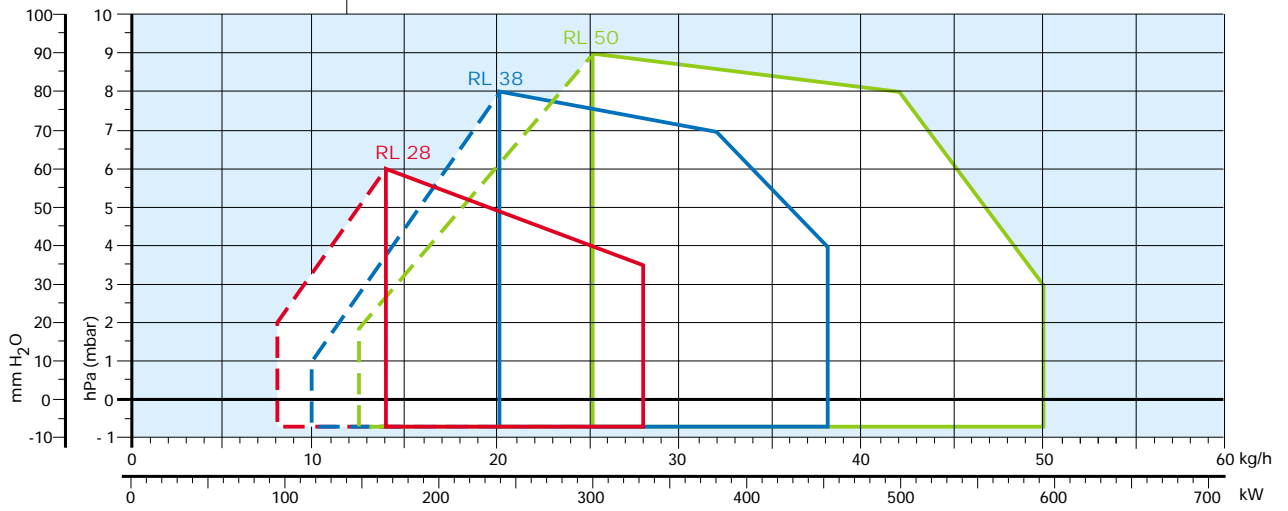

Useful working field for choosing the burner

1st stage operating rate

Test conditions conforming to EN 267:
 Temperature: 20°C
 Pressure: 1013.5 mbar
 Altitude: 100 m a.s.l.

FUEL SUPPLY



HYDRAULIC CIRCUITS

The burners are fitted with three valves (a safety valve and two oil delivery valves).

A control device, on the basis of required output, regulates oil delivery valves opening, allowing light oil passage through the valves and the nozzle.

Delivery valves opening supplies the two-stage hydraulic ram which regulates air delivery in relation to the fuel burnt. The pumping group is fitted with a pump, an oil filter and a regulating valve, that adjust atomised pressure.

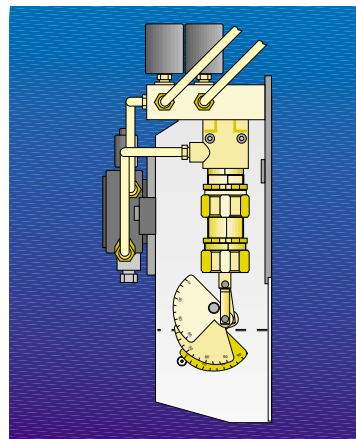

Example of adjustable hydraulic ram of RL 70 - 100 - 130 burners

P	Pump with filter and pressure regulator on the output circuit
VS	Safety valve on the output circuit
VF1	1st stage valve
VF2	2nd stage valve
VC	2nd stage control device
MT	Hydraulic ram
AD	Air damper
U1	1st stage nozzle
U2	2nd stage nozzle

RL 28

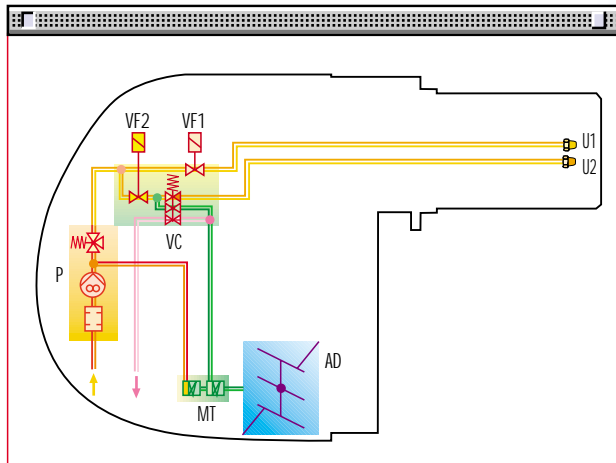

RL 38 - 50

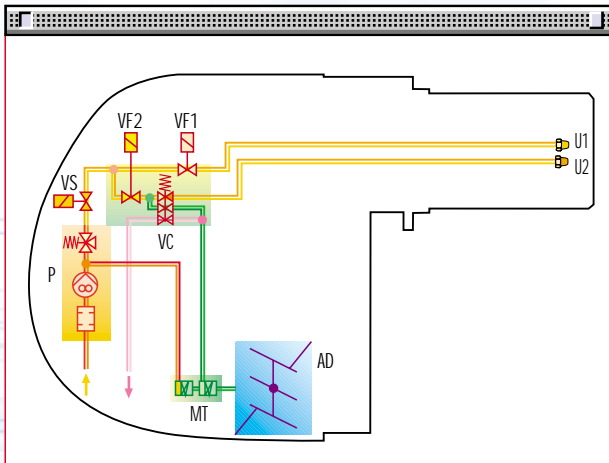

RL 70 - 100 - 130

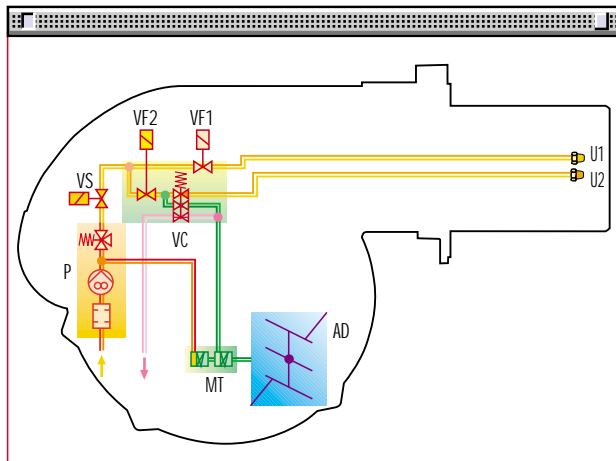

RL 190

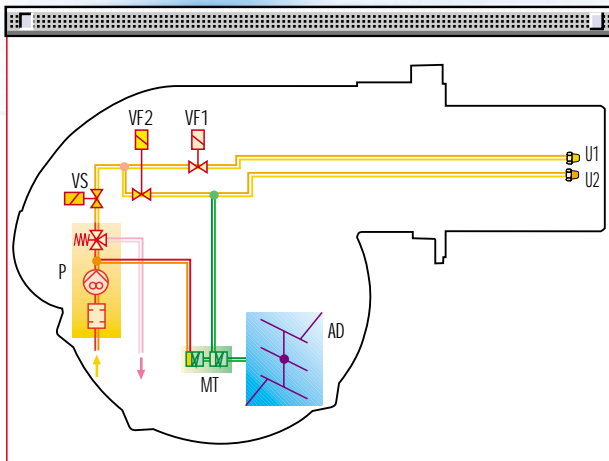



DIMENSIONING OF THE FUEL SUPPLY LINES

The fuel feed must be completed with the safety devices required by the local norms.

The table shows the choice of piping diameter for the various burners, depending on the difference in height between the burner and the tank and their distance.

MAXIMUM EQUIVALENT LENGTH FOR THE PIPING L[m]											
Model	▼ RL 28			▼ RL 38 - 50			▼ RL 70 - 100 - 130			▼ RL 190	
Diameter piping	Ø10mm	Ø12mm	Ø14mm	Ø10mm	Ø12mm	Ø14mm	Ø12mm	Ø14mm	Ø16mm	Ø16mm	Ø18mm
+H, -H (m)	L _{max} (m)	L _{max} (m)	L _{max} (m)	L _{max} (m)	L _{max} (m)	L _{max} (m)	L _{max} (m)	L _{max} (m)	L _{max} (m)	L _{max} (m)	L _{max} (m)
+4,0	63	144	150	51	112	150	71	138	150	60	80
+3,0	55	127	150	46	99	150	62	122	150	50	70
+2,0	48	111	150	39	86	150	58	106	150	40	60
+1,5	44	102	150	35	79	147	51	98	150	35	55
+1,0	40	94	150	32	73	144	44	90	150	30	50
+0,5	37	86	150	29	65	132	40	82	150	25	45
0	33	78	150	26	60	120	36	74	137	20	40
-0,5	29	70	133	23	54	106	32	66	123	18	35
-1,0	25	82	118	20	47	96	28	56	109	15	30
-1,5	21	63	103	16	40	83	23	49	95	13	25
-2,0	17	45	88	13	34	71	19	42	81	10	20
-3,0	10	29	58	7	21	46	10	26	53	5	10
-4,0	4	12	28	2	8	21	3	10	25	3	6

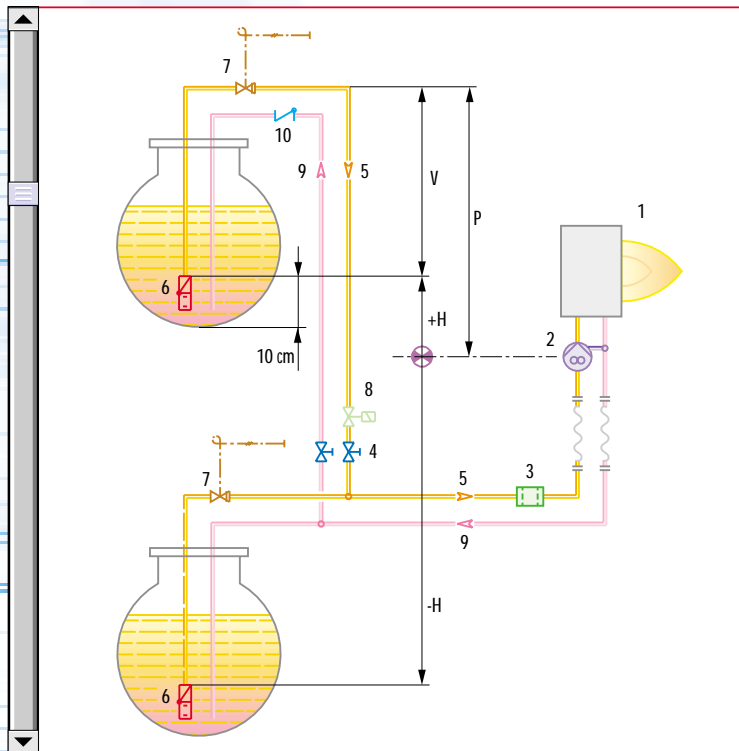

H	Difference in height pump-foot valve
Ø	Internal pipe diameter
P	Height 10 m
V	Height 4 m
1	Burner
2	Burner pump
3	Filter
4	Manual shut off valve
5	Suction pipework
6	Bottom valve
7	Remote controlled rapid manual shut off valve (compulsory in Italy)
8	Type approved shut off solenoid valve (compulsory in Italy)
9	Return pipework
10	Check valve

note

With ring distribution oil systems, the feasible drawings and dimensioning are the responsibility of specialised engineering studios, who must check compatibility with the requirements and features of each single installation.



VENTILATION

The ventilation circuit produces low noise levels with high performance pressure and air output, in spite of the compact dimensions.

Except for the RL 190 model, the use of reverse curve blades and sound proofing material keeps noise level very low.

In the RL 190 model, sound has been reduced by the special design of the air suction circuit.

An hydraulic ram allows to have a right air flow in any operational moment and the closure of the air damper with burner in stand-by.



Example of the air damper on RL 28 - 38 - 50 burners



COMBUSTION HEAD

Different lengths of the combustion head can be chosen for the RL series of burners.

The choice depends on the thickness of the front panel and the type of boiler.

Depending on the type of generator, check that the penetration of the head into the combustion chamber is correct.

The internal position of the combustion head can easily be adjusted to the maximum defined output by adjusting a screw fixed to the flange.

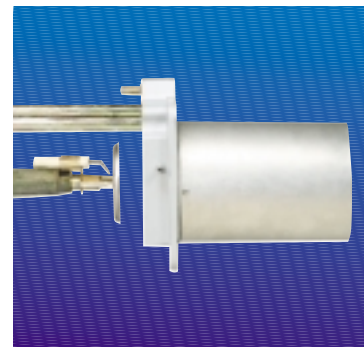

Example of a RL burner combustion head

Dimensions of the flame

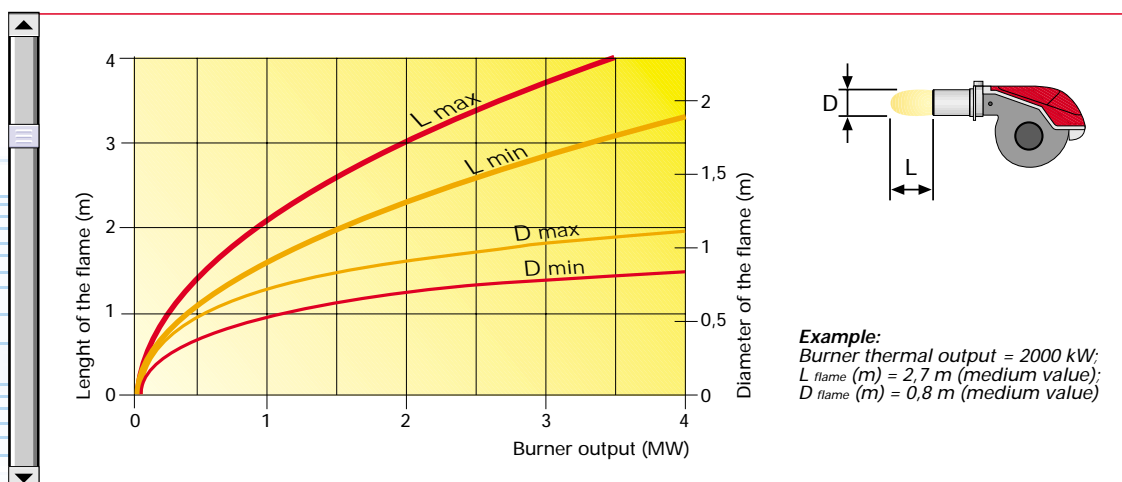



ELECTRICAL CONNECTIONS to be made by the installer

Electrical connections must be made by qualified and skilled personnel, according to the local norms.



Example of the terminal board for electrical connections on RL 28 - 38 burners

" TWO STAGE " OPERATION

RL 28 - 38 single-phase electrical connection

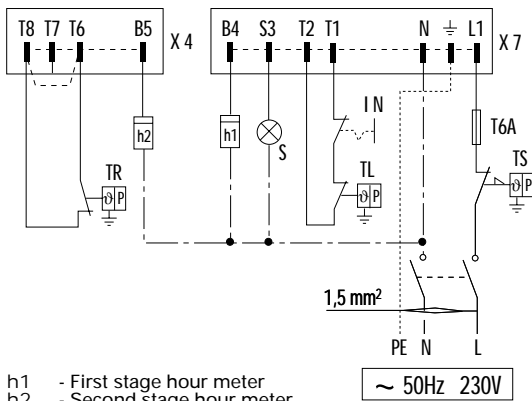

- h1 - First stage hour meter
- h2 - Second stage hour meter
- IN - Manual switch
- X4 - 4 pin plug
- X7 - 7 pin plug
- S - External lock-out signal
- TL - Threshold thermostat
- TR - High/low flame setting thermostat
- TS - Safety thermostat
- T6A - 6a fuse

RL 38 - 50 three-phase electrical connection

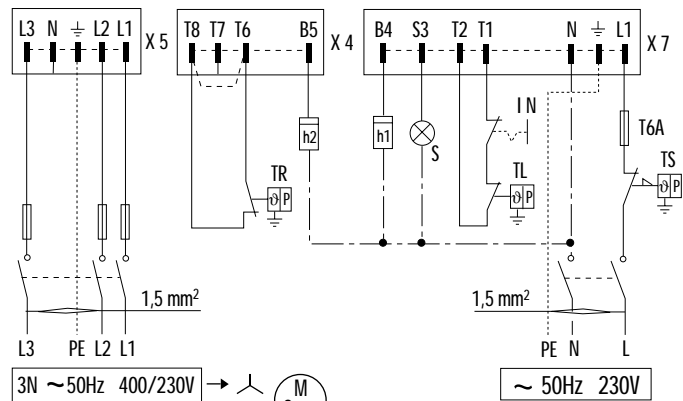

- h1 - First stage hour meter
- h2 - Second stage hour meter
- IN - Manual switch
- X4 - 4 pin plug
- X5 - 5 pin plug
- X7 - 7 pin plug
- S - External lock-out signal
- TL - Threshold thermostat
- TR - High/low flame setting thermostat
- TS - Safety thermostat
- T6A - 6a fuse

RL 70 - 100 - 130 - 190 three-phase electrical connection

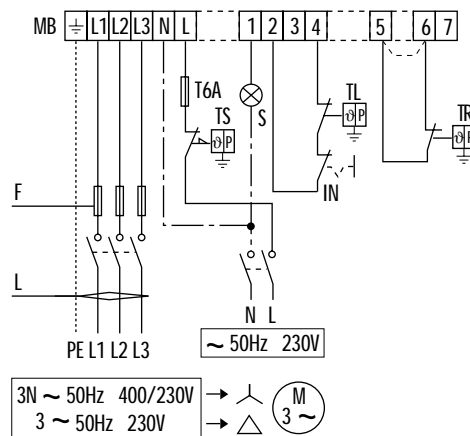

- MB - Burner terminal board
- TS - Safety thermostat
- S - External lock-out signal
- IN - Manual switch
- TL - Threshold thermostat
- TR - High/low flame setting thermostat
- T6A - 6A fuse
- F - Fuse (see table A)
- L - Lead section (see table A)

The following table shows the supply lead sections and the type of fuse to be used.

Model	▼RL 28	▼RL 38	▼RL 38	▼RL 50	▼RL 70	▼RL 100	▼RL 130	▼RL 190
	230V	230V	230V	400V	230V	400V	230V	400V
F A	T6	T6	T6	T6	T6	T10	T16	T10
L mm ²	1,5	1,5	1,5	1,5	1,5	1,5	1,5	2,5

Table A

EMISSIONS

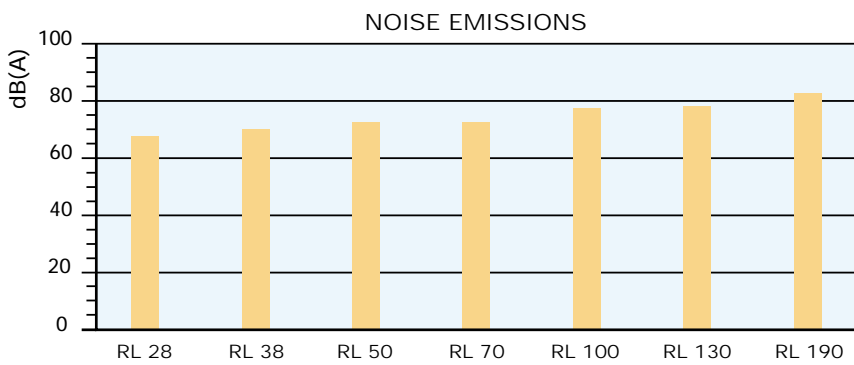
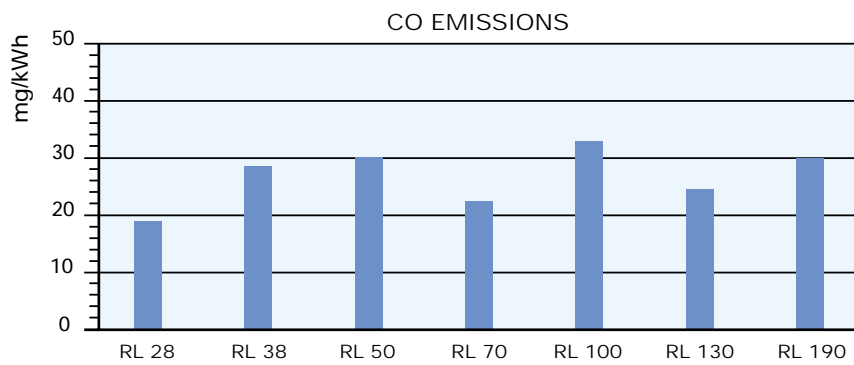
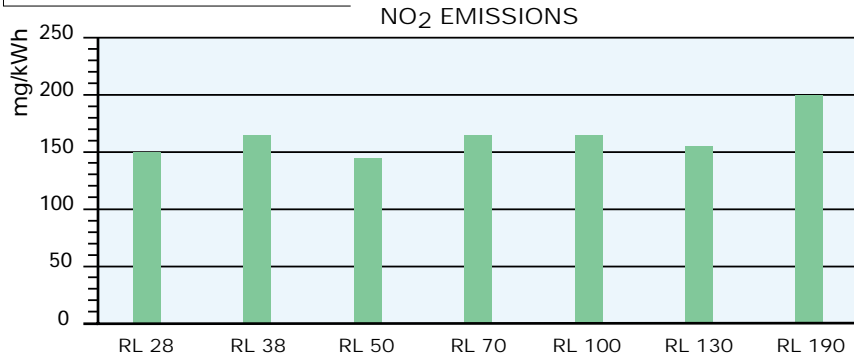

The emission data has been measured in the various models at maximum output, according to EN 267 standard.



OVERALL DIMENSIONS (mm)

BURNERS

RL 28 - 38 - 50

RL 70 - 100 - 130 - 190

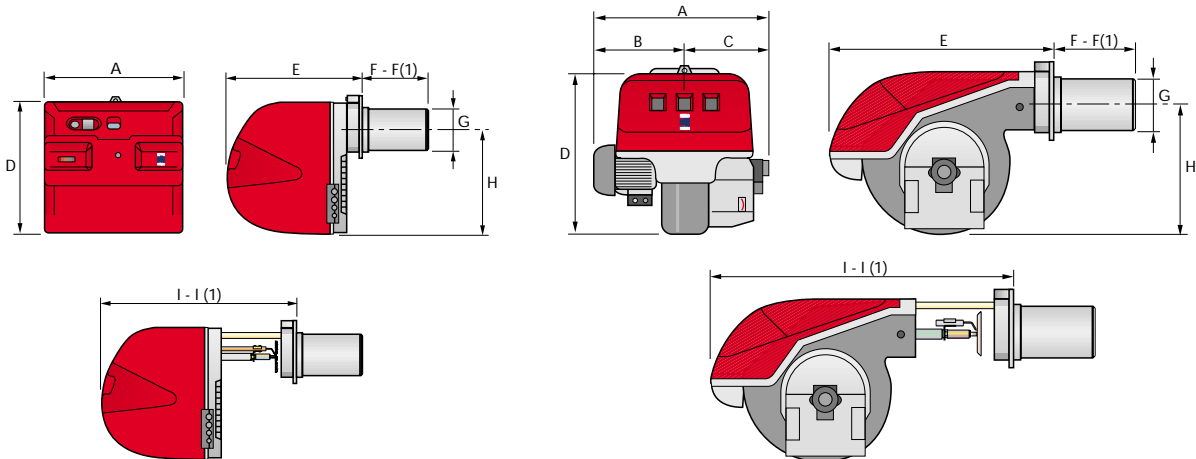

Model	A	B	C	D	E	F - F (1)	G	H	I - I (1)
▶ RL 28	476	-	-	474	468	216 - 351	140	352	672 - 807
▶ RL 38	476	-	-	474	468	216 - 351	140	352	672 - 807
▶ RL 50	476	-	-	474	468	216 - 351	140	352	672 - 807
▶ RL 70	580	296	284	555	680	250 - 385	179	430	951 - 1086
▶ RL 100	599	312	287	555	680	250 - 385	179	430	951 - 1086
▶ RL 130	625	338	287	555	680	250 - 385	189	430	951 - 1086
▶ RL 190	756	366	390	555	696	370 -	222	430	1102 -

(1) dimension with extended head

BURNER - BOILER MOUNTING FLANGE

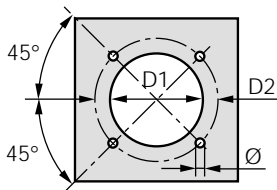

Model	D1	D2	Ø
▶ RL 28	160	224	M8
▶ RL 38	160	224	M8
▶ RL 50	160	224	M8
▶ RL 70	185	275-325	M12
▶ RL 100	185	275-325	M12
▶ RL 130	195	275-325	M12
▶ RL 190	230	325-368	M16

PACKAGING

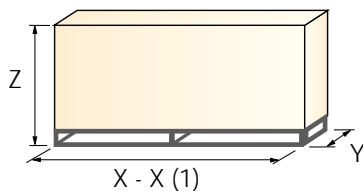

Model	X - X (1)	Y	Z	kg
▶ RL 28	760 - 895	540	550	36
▶ RL 38	760 - 895	540	550	38
▶ RL 50	760 - 895	540	550	39
▶ RL 70	960 - 1150	652	600	60
▶ RL 100	960 - 1150	652	600	63
▶ RL 130	960 - 1150	652	600	66
▶ RL 190	1250	725	785	75

(1) dimension with extended head

INSTALLATION DESCRIPTION

Installation, start up and maintenance must be carried out by qualified and skilled personnel. All operations must be performed in accordance with the technical handbook supplied with the burner.



BURNER SETTING

- ▶ All the burners have slide bars, for easier installation and maintenance.
- ▶ After drilling the boilerplate, using the supplied gasket as a template, dismantle the blast tube from the burner and fix it to the boiler.
- ▶ Adjust the combustion head.
- ▶ Refit the burner casing to the slide bars.
- ▶ Install the nozzle, choosing this on the basis of the maximum boiler output and following the diagrams included in the burner instruction handbook.
- ▶ Check the position of the electrodes.
- ▶ Close the burner, sliding it up to the flange, keeping it slightly raised to avoid the flame stability disk rubbing against the blast tube.



HYDRAULIC AND ELECTRICAL CONNECTIONS AND START UP

- ▶ The burners are supplied for connection to two pipes fuel supply system.
- ▶ Connect the ends of the flexible pipes to the suction and return pipework using the supplied nipples.
- ▶ Make the electrical connections to the burner following the wiring diagrams included in the instruction handbook.
- ▶ Prime the pump by turning the motor.
- ▶ On start up, check:
 - Pressure pump (to max. and min.)
 - Combustion quality, in terms of unburned substances and excess air.





ACCESSORIES



Nozzles

The nozzles must be ordered separately. The following table shows the features and codes on the basis of the maximum required fuel output.



Nozzles type 60° B					
Burner	GPH	Rated output (kg/h)			Nozzle code
		at 10 bar	at 12 bar	at 14 bar	
RL 28	2,00	7,7	8,5	9,2	3042126
RL 28-38	2,50	9,6	10,6	11,5	3042140
RL 28-38-50	3,00	11,5	12,7	13,8	3042158
RL 28-38-50	3,50	13,5	14,8	16,1	3042162
RL 38-50	4,00	15,4	17	18,4	3042172
RL 38-50	4,50	17,3	19,1	20,7	3042182
RL 38-50-70	5,00	19,2	21,2	23	3042192
RL 50-70	5,50	21,1	23,3	25,3	3042202
RL 50-70	6,00	23,1	25,5	27,7	3042212
RL 50-70	6,50	25	27,6	30	3042222
RL 70-100	7,00	26,9	29,7	32,3	3042232
RL 70-100	7,50	28,8	31,8	34,6	3042242
RL 70-100	8,00	30,8	33,9	36,9	3042252
RL 70-100	8,50	32,7	36,1	39,2	3042262
RL 70-100-130	9,50	36,5	40,3	43,8	3042282
RL 70-100-130-190	10,00	38,4	42,4	46,1	3042292
RL 70-100-130-190	11,00	42,3	46,7	50,7	3042312
RL 100-130-190	12,00	46,1	50,9	55,3	3042322
RL 100-130-190	13,00	50	55,1	59,9	3042332
RL 100-130-190	14,00	53,8	59,4	64,5	3042352
RL 100-130-190	15,00	57,7	63,6	69,2	3042362
RL 100-130-190	16,00	61,5	67,9	73,8	3042382
RL 130-190	17,00	65,4	72,1	78,4	3042392
RL 130-190	18,00	69,2	76,4	83	3042412
RL 130-190	19,00	73	80,6	87,6	3042422
RL 130-190	20,00	76,9	84,8	92,2	3042442
RL 190	22,00	84,6	93,3	101,4	3042462
RL 190	24,00	92,2	101,8	110,6	3042472
RL 190	26,00	99,9	110,3	119,9	3042482
RL 190	28,00	107,6	118,8	129,1	3042492



Extended heads

“Standard head” burners can be transformed into “extended head” versions, by using the special kit. The kits available for the various burners, giving the original and the extended lengths, are listed below.

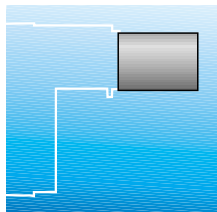

Combustion head extension kits			
Burner	'Standard' head length (mm)	'Extended' head length (mm)	Kit code
RL 28	216	351	3010073
RL 38	216	351	3010074
RL 50	216	351	3010075
RL 70	250	385	3010114
RL 100	250	385	3010115
RL 130	250	385	3010116
RL 190	370	-	-

Spacer kit

If burner head penetration into the combustion chamber needs reducing, varying thickness spacers are available, as given in the following table:

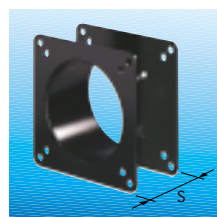

Head length reduction kit		
Burner	Spacer thickness S (mm)	Kit code
RL 28 - 38 - 50	90	3010095
RL 70 - 100 - 130	135	3010129
RL 190	110	3000722

Sound proofing box

If noise emission needs reducing even further, sound-proofing boxes are available, as given in the following table:



Sound proofing box		
Burner	Box type	Box code
RL 28 - 38 - 50	C1	3000776
RL 70 - 100 - 130	C3	3000778
RL 190	C4	3000779

Degasing unit

With single pipe systems, you can find air in the oil sucked by the pump that comes from the oil itself due to negative pressure or to a faulty seal.

To solve this problem, we recommend fitting a degasing unit near the burner. Two versions are available with or without filter:



Degasing unit		
Burner	Degasing unit with filter Code	Degasing unit without filter Code
RL 28 - 38 - 50 RL 70 - 100 - 130 - 190	3010055	3010054



SPECIFICATION

A specific index guides your choice of burner from the various models available in the RL series. Below is a clear and detailed specification description of the product.

DESIGNATION OF SERIES R BURNERS

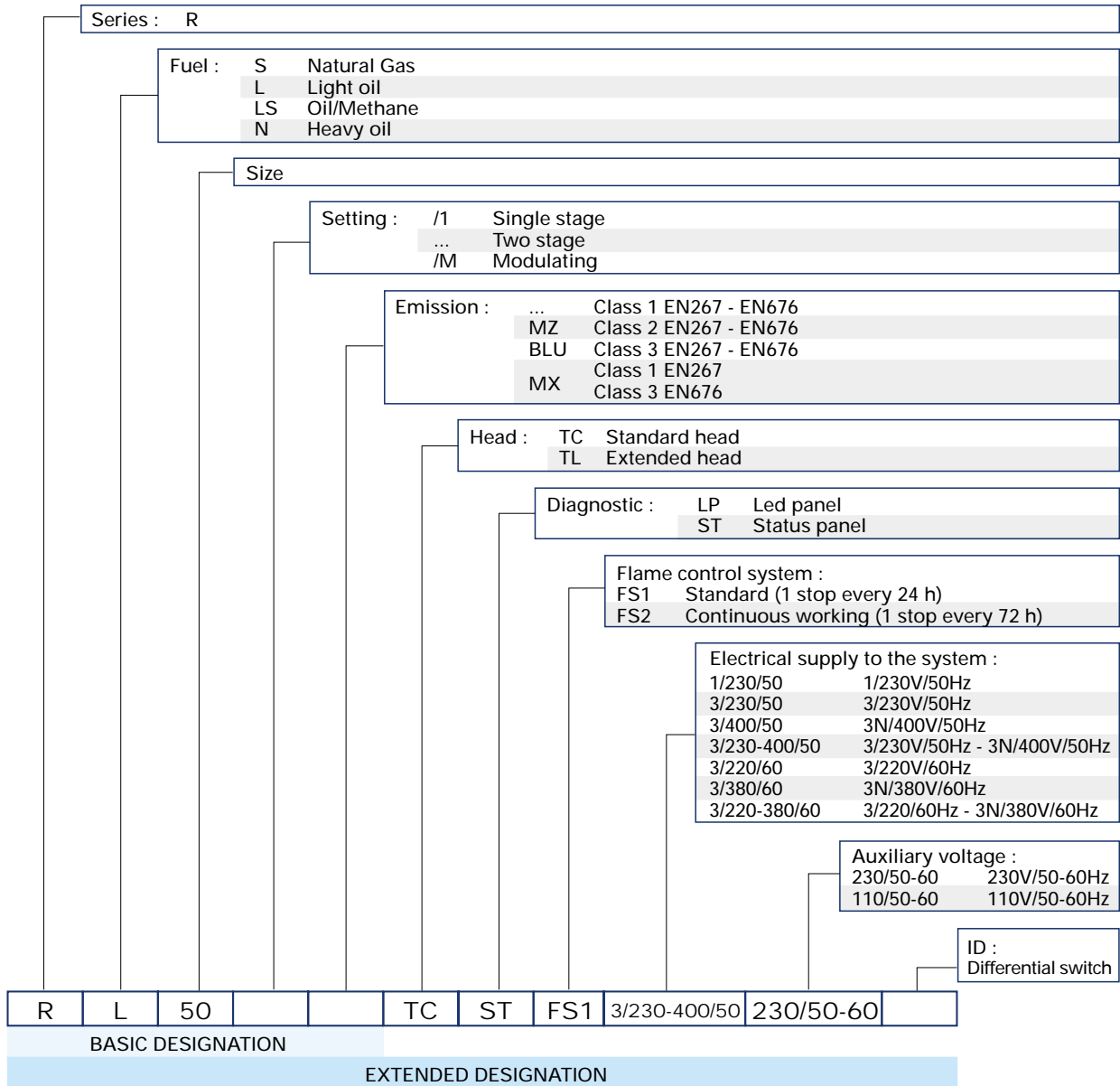

LIST OF AVAILABLE MODELS

RL 28	TC	ST	FS1	1/230/50	230/50-60	RL 70	TC	ST	FS1	3/230-400/50	230/50-60
RL 28	TL	ST	FS1	1/230/50	230/50-60	RL 70	TL	ST	FS1	3/230-400/50	230/50-60
RL 28	TC	LP	FS1	1/230/50	230/50-60	RL 70	TC	LP	FS1	3/230-400/50	230/50-60
RL 28	TL	LP	FS1	1/230/50	230/50-60	RL 70	TL	LP	FS1	3/230-400/50	230/50-60
RL 38	TC	ST	FS1	1/230/50	230/50-60	RL 100	TC	ST	FS1	3/230-400/50	230/50-60
RL 38	TL	ST	FS1	1/230/50	230/50-60	RL 100	TL	ST	FS1	3/230-400/50	230/50-60
RL 38	TC	LP	FS1	1/230/50	230/50-60	RL 100	TC	LP	FS1	3/230-400/50	230/50-60
RL 38	TL	LP	FS1	1/230/50	230/50-60	RL 100	TL	LP	FS1	3/230-400/50	230/50-60
RL 38	TC	ST	FS1	3/230-400/50	230/50-60	RL 130	TC	ST	FS1	3/230-400/50	230/50-60
RL 38	TL	ST	FS1	3/230-400/50	230/50-60	RL 130	TL	ST	FS1	3/230-400/50	230/50-60
RL 38	TC	LP	FS1	3/230-400/50	230/50-60	RL 130	TC	LP	FS1	3/230-400/50	230/50-60
RL 38	TL	LP	FS1	3/230-400/50	230/50-60	RL 130	TL	LP	FS1	3/230-400/50	230/50-60
RL 50	TC	ST	FS1	3/230-400/50	230/50-60	RL 190	TC	ST	FS1	3/230-400/50	230/50-60
RL 50	TL	ST	FS1	3/230-400/50	230/50-60						
RL 50	TC	LP	FS1	3/230-400/50	230/50-60						
RL 50	TL	LP	FS1	3/230-400/50	230/50-60						

Other versions are available on request.



▶ PRODUCT SPECIFICATION

Burner:

Monoblock forced draught oil burner with two stage operation, fully automatic, made up of:

- Air suction circuit lined with sound-proofing material
- Fan with reverse curve blades (straight blades on the 190 model) high performance with low sound emissions
- Air damper for air setting controlled by an adjustable hydraulic ram
- Starting motor at 2800 rpm, three-phase 400V with neutral, 50Hz (single-phase, 230V and 50Hz for the 28 - 38 models)
- Combustion head, that can be set on the basis of required output, fitted with:
 - stainless steel end cone, resistant to corrosion and high temperatures
 - ignition electrodes
 - flame stability disk
- Gears pump for high pressure fuel supply, fitted with:
 - filter
 - pressure regulator
 - connections for installing a pressure gauge and vacuumeter
 - internal by-pass for single pipe installation
- Valve unit with an oil safety valve and two delivery oil valves on the output circuit
- Photocell for flame detection
- Flame control panel, with lock-out pilot light and lock-out reset button
- Electronic control device: status panel or led panel
- Burner on/off switch
- Flame inspection window
- 1st - 2nd stage manual switch
- Slide bars for easier installation and maintenance
- Protection filter against radio interference
- IP 44 electric protection level.

Conforming to:

- 89/336/EEC directive (electromagnetic compatibility)
- 73/23/EEC directive (low voltage)
- 92/42/EEC directive (performance)
- 98/37/EEC directive (machinery)
- EN 267 (liquid fuel burners).

Standard equipment:

- 2 flexible pipes for connection to the oil supply network
- 2 gaskets for the flexible pipes
- 2 nipples for connection to the pump
- 4 screws for fixing the burner flange to the boiler
- 1 thermal screen
- Fairleads for electrical connections (RL 28 - 38 - 50 models)
- 2 slide bar extensions (for the extended head models and the RL 190 model)
- Instruction handbook for installation, use and maintenance
- Spare parts catalogue.

Available accessories to be ordered separately:

- Nozzles
- Head extension kit (except for the RL 190 model)
- Head length reduction kit
- Sound-proofing box
- Degassing unit (with or without filter).



RIELLO S.p.A. - Via degli Alpini, 1 - 37045 LEGNAGO (VR) Italy
Tel. ++39.0442630111 - Fax ++39.044221980

Internet: <http://www.rielloburners.com> - E-mail: rburners@rielloburners.com



Since the Company is constantly engaged in the production improvement, the aesthetic and dimensional features, the technical data, the equipment and the accessories can be changed.
This document contains confidential and proprietary information of RIELLO S.p.A.
Unless authorised, this information shall not be divulged, nor duplicated in whole or in part.